

BioChop[®]

Fast and efficient
processing of
organic by-products
and waste



LANDIA
CHOPPER PUMPS
NEVER GIVE UP

Landia[®]

Complete systems for treatment of organic by-products, remnants and waste from:

- food industry
- fish industry
- poultry processing industry
- catering, restaurants etc.
- vegetable and fruit processing industry
- wastewater treatment plants

BioChop can handle:

- abattoir waste
- fish waste
- gastric/intestine contents
- intestines
- vegetable and fruit waste
- raw septic sewage
- other remnants



The organic by-products are added to the tank, chopped, mixed and made pumpable in one process by a powerful chopper pump. With the use of **BioChop** coarse dry matter particles will be chopped/macerated efficiently. After sufficient processing and mixing of the medium, the product is now easy to handle and can be pumped further on in the system to e.g. a storage tank or a tanker, simply by switching the pump from its chopping/mixing function to pumping.



Before



After

Advantages:

BioChop systems represent a new, cost-effective way to process by-products and waste in a great variety of different industries. Every **BioChop** is customized to the clients' specific needs. Compared to traditional methods, the Landia **BioChop** system offers reduced cost for waste disposal, manpower and transport as well as ensures a cleaner working environment. The final product is pumpable and easy to handle. In many situations it can be recycled as a valuable raw material used in e.g. mink and petfood production or as an energy-rich substrate at biogas plants.

Preservation:

By means of acid the by-products can be preserved after the **BioChop** process, if storage is required for a longer period of time. Landia supplies complete process plants with acid dosage equipment.

BioChop[®]

Technical data – process plant:

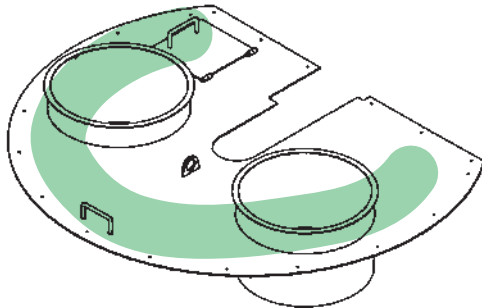

- Chopper pump and process tank of acidproof stainless steel
- Cover with opening for manual or automatic filling
- Volume 2.6 m³ – other sizes available
- Chopping system for efficient chopping
- Non-clog pump casing and impeller

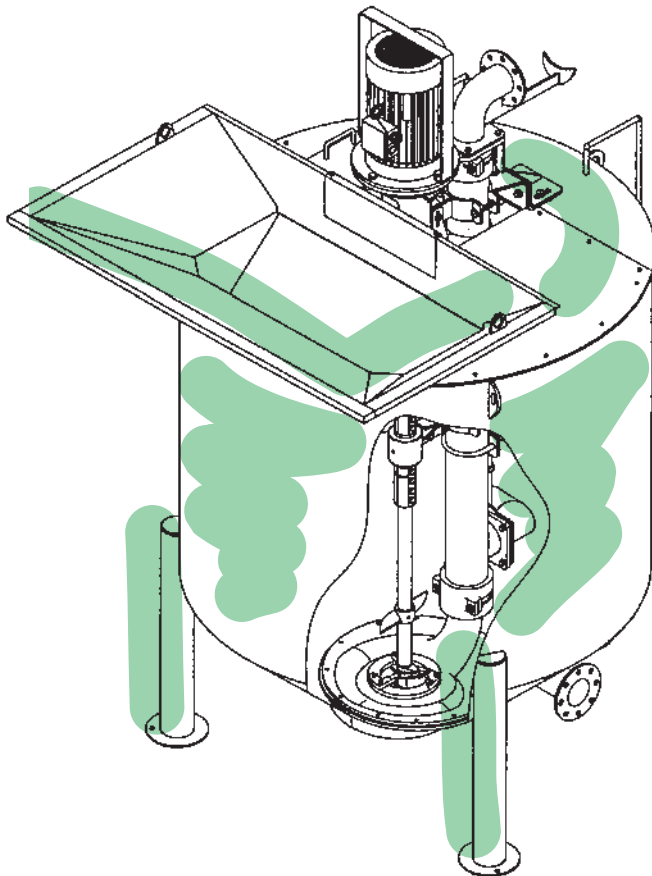

Optional equipment:

- Complete control system
- Acid dosage equipment
- Load cells
- Automatic interior flushing

Landia has more than 70 years of experience offering solutions and systems for the treatment of difficult mediums. We undertake the tasks which demand the specialist's proficiency and we solve problems within e.g. chopping and pumping, mixing and aeration in industrial processes and wastewater treatment. Landia produces process plants, submersible mixers as well as chopper pumps with a unique chopping system.

LANDIA A/S
DENMARK
ISO 9001

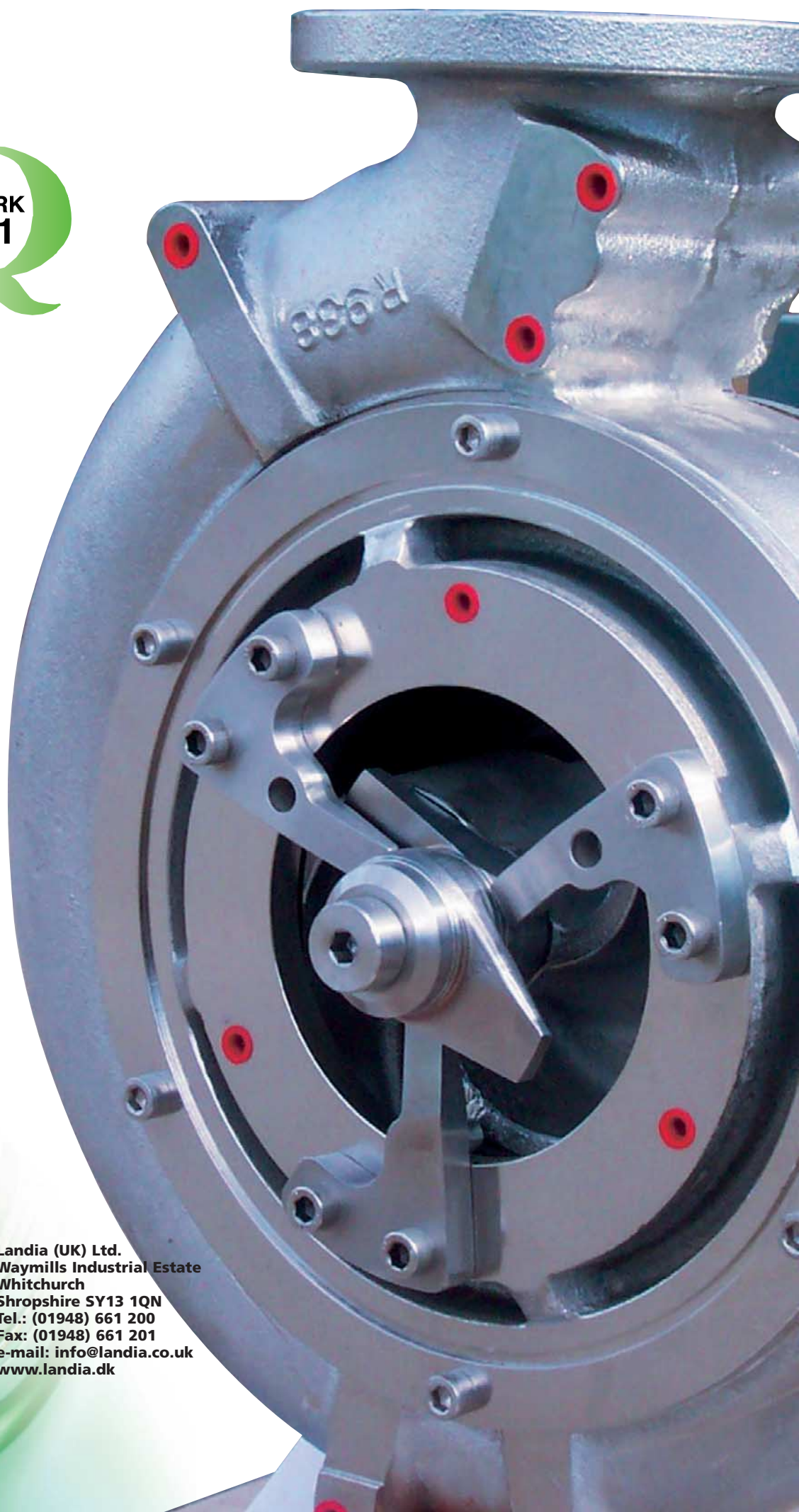

Landia[®]

Headquarter:
Landia A/S
Industrivej 2
DK-6940 Lem St.
Tel.: +45 97 34 12 44
Fax: +45 97 34 16 98
e-mail: info@landia.dk
www.landia.dk

Landia (UK) Ltd.
Waymills Industrial Estate
Whitchurch
Shropshire SY13 1QN
Tel.: (01948) 661 200
Fax: (01948) 661 201
e-mail: info@landia.co.uk
www.landia.dk